

Seenpin 新剑



**六自由度机械臂
装配教程**

警告、注意事项

- 智能柔性关节及整臂不适用于潮湿、多尘的环境；
- 操作期间应避免整臂及柔性关节与外物发生猛烈碰撞；
- 连接装配期间应在断电的情况下进行；
- 应避免整臂在运行中突然断掉；
- 不得擅自拆解智能柔性关节，造成保修失效；

技术参数

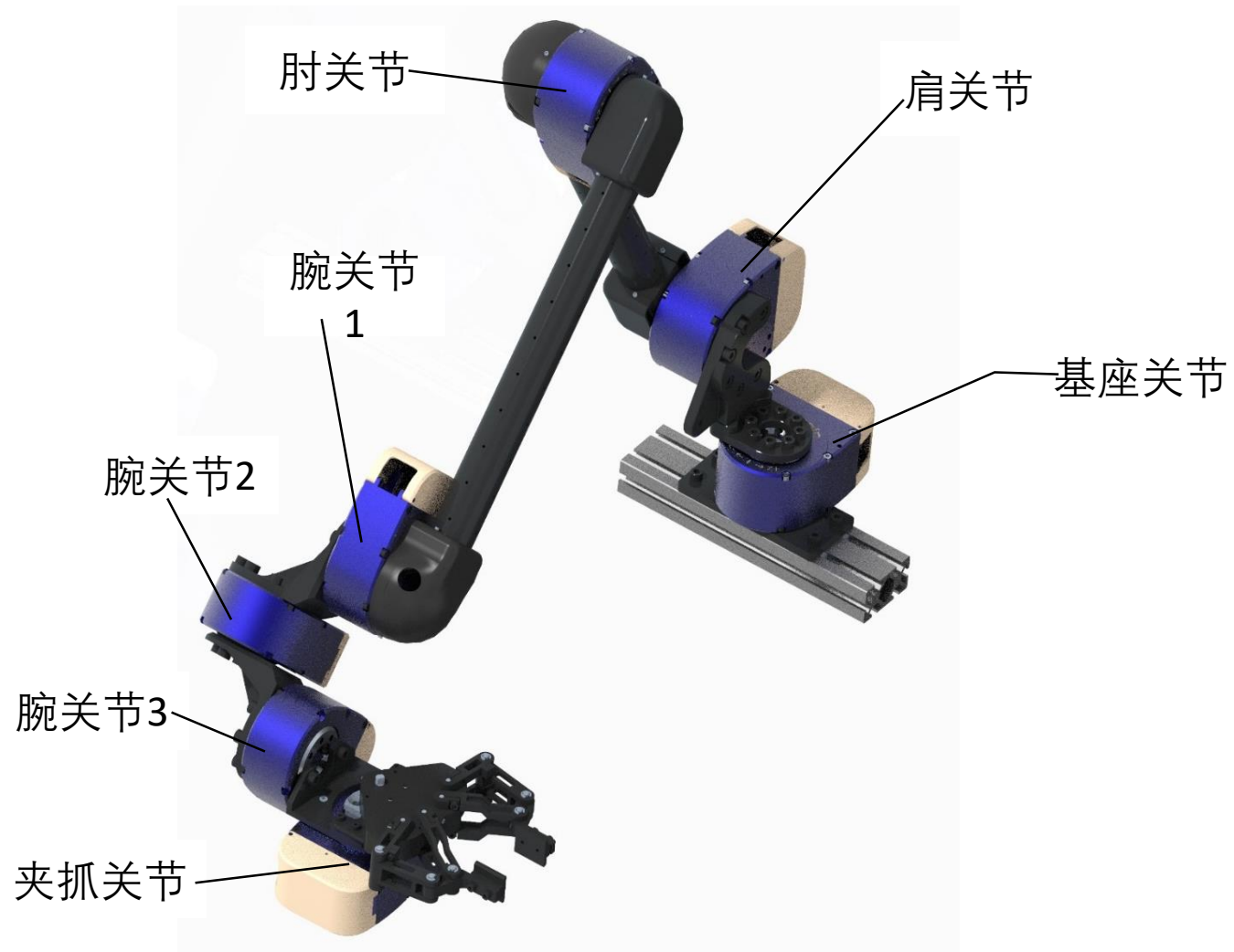

技术参数

- 全展俯视图

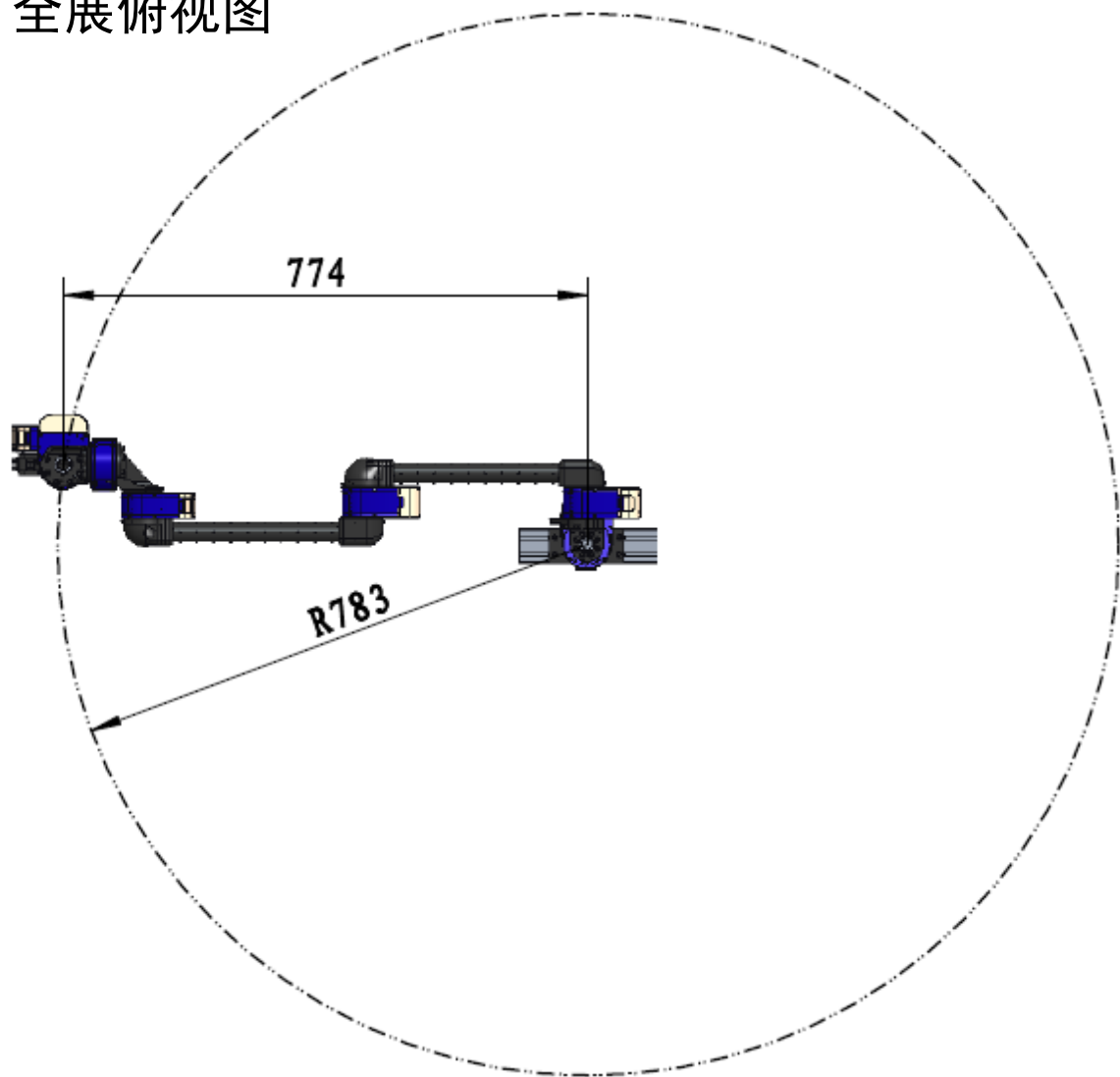

- 全展侧视图

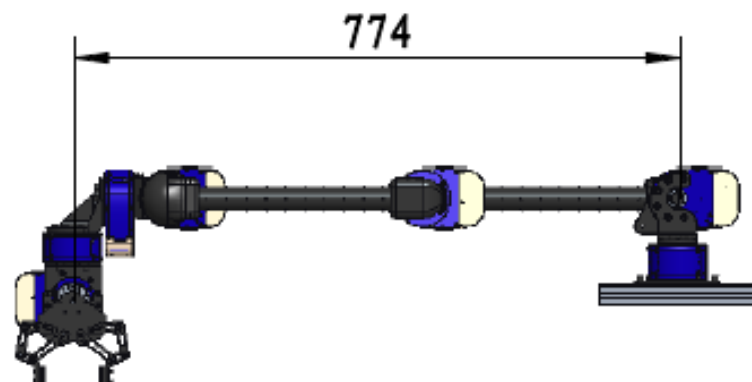

- 半展侧视图

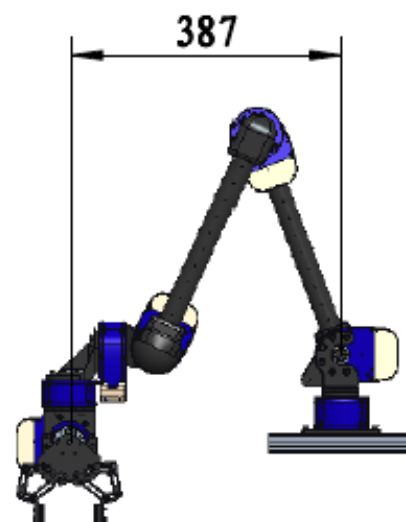

技术参数

- 夹抓尺寸

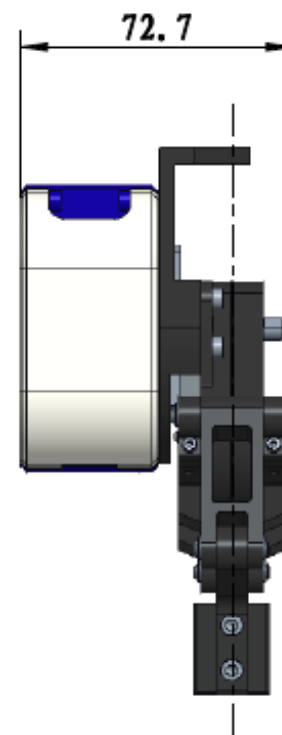
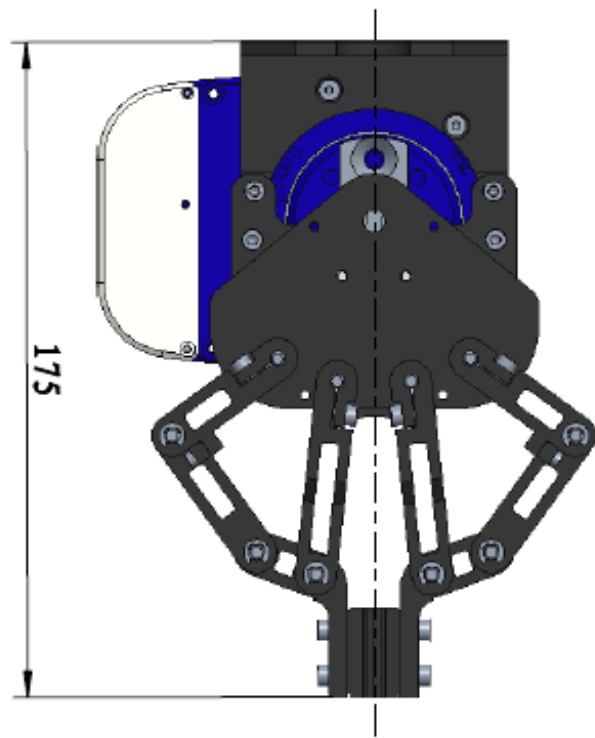
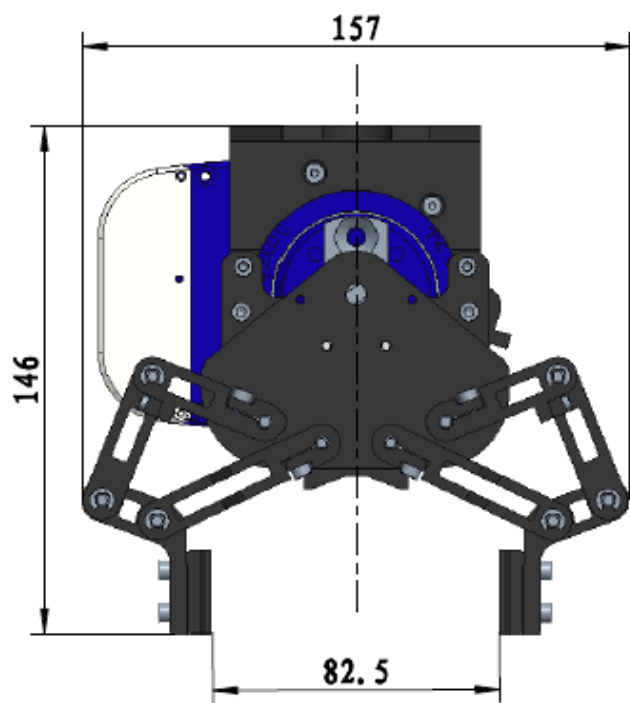

技术参数

- 夹抓运动参数

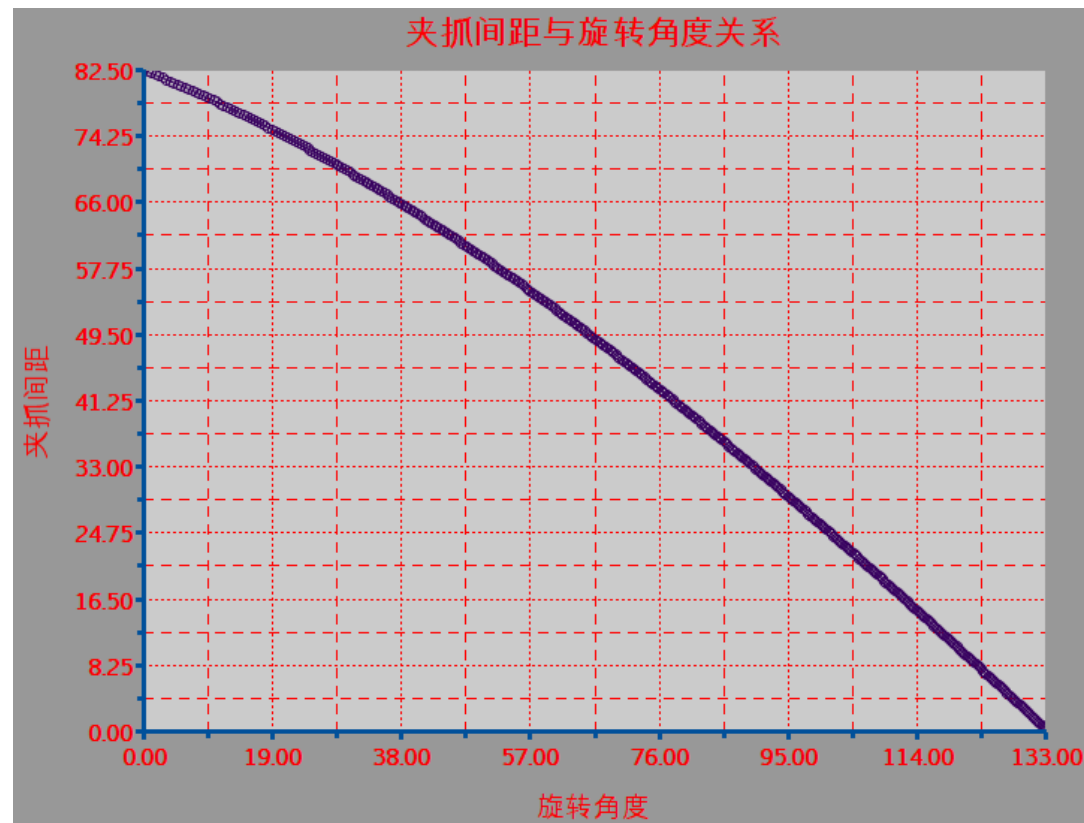
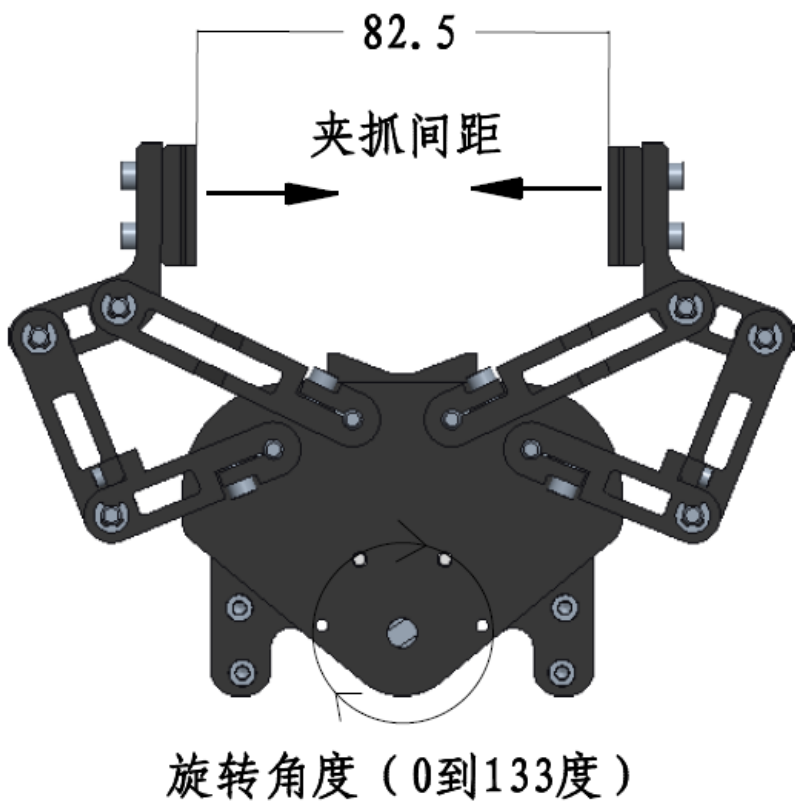

技术参数

- 夹抓夹持力参数

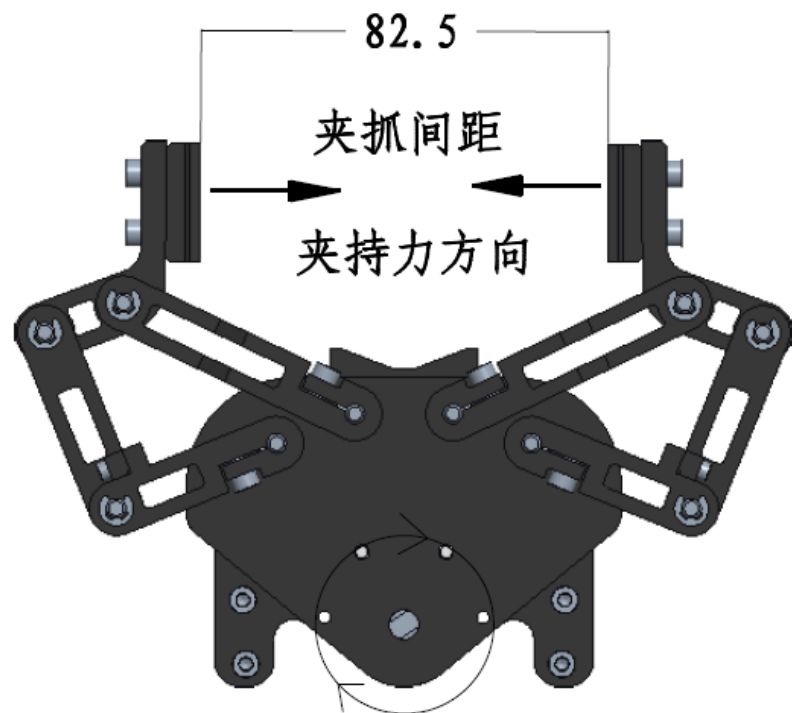

旋转角度 (0到133度)
扭矩1NM恒定输入

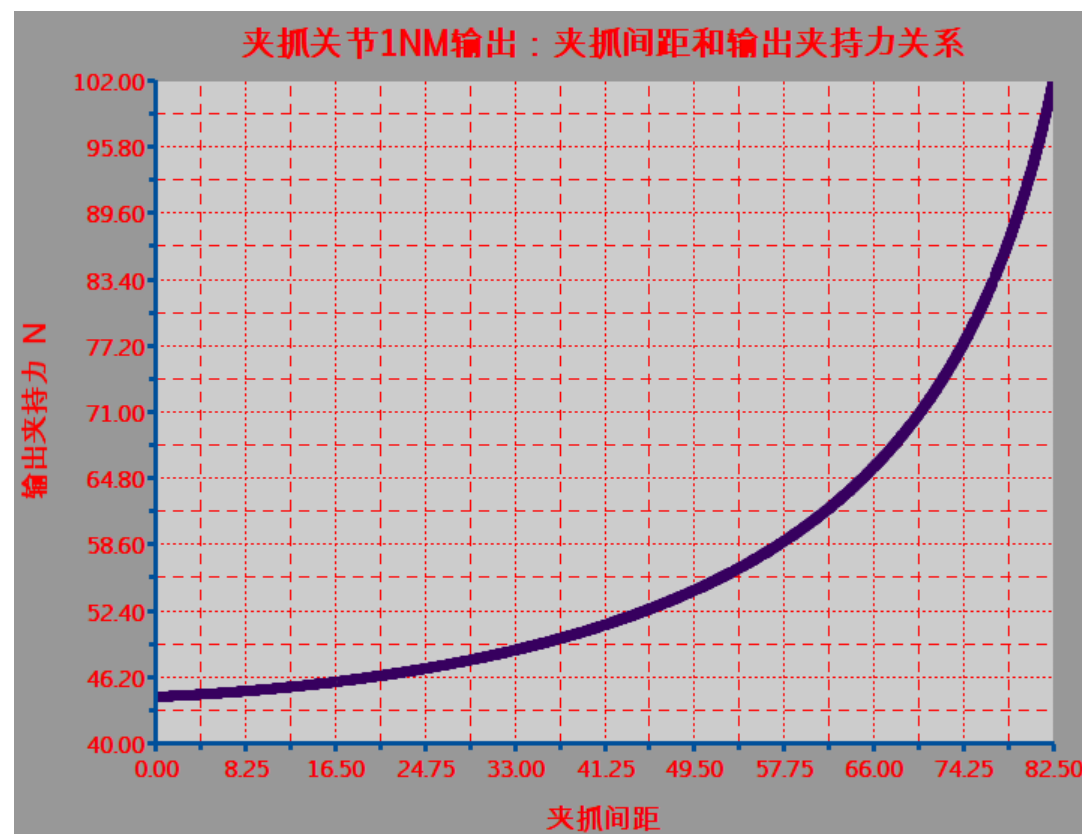

整臂机械配件

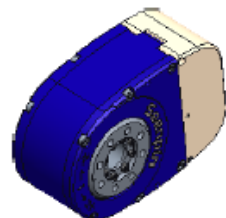

1X XGA/2X XGD

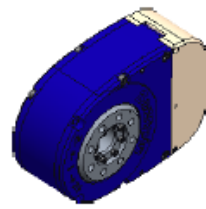

3X XGB

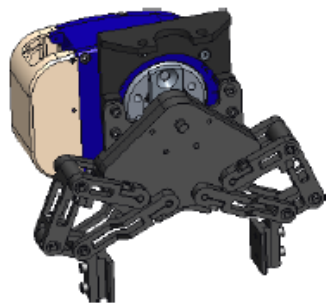

1X 夹抓组件

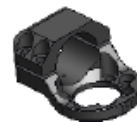

2X 法兰连接组件



2X 底座连接组件



3X 腕部连接件



1X 底板



1X 连接座组件



2X 方形外罩壳



2X 圆形外罩壳

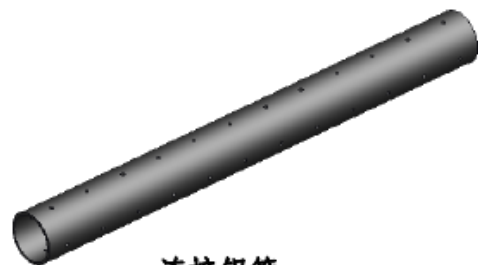

连接铝管

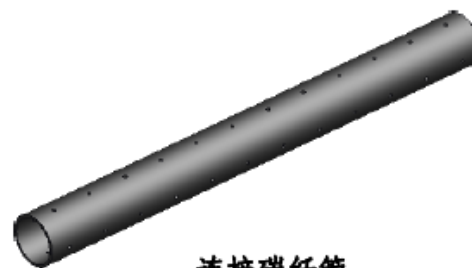

连接碳纤维管

整臂装配顺序

- 基座装配

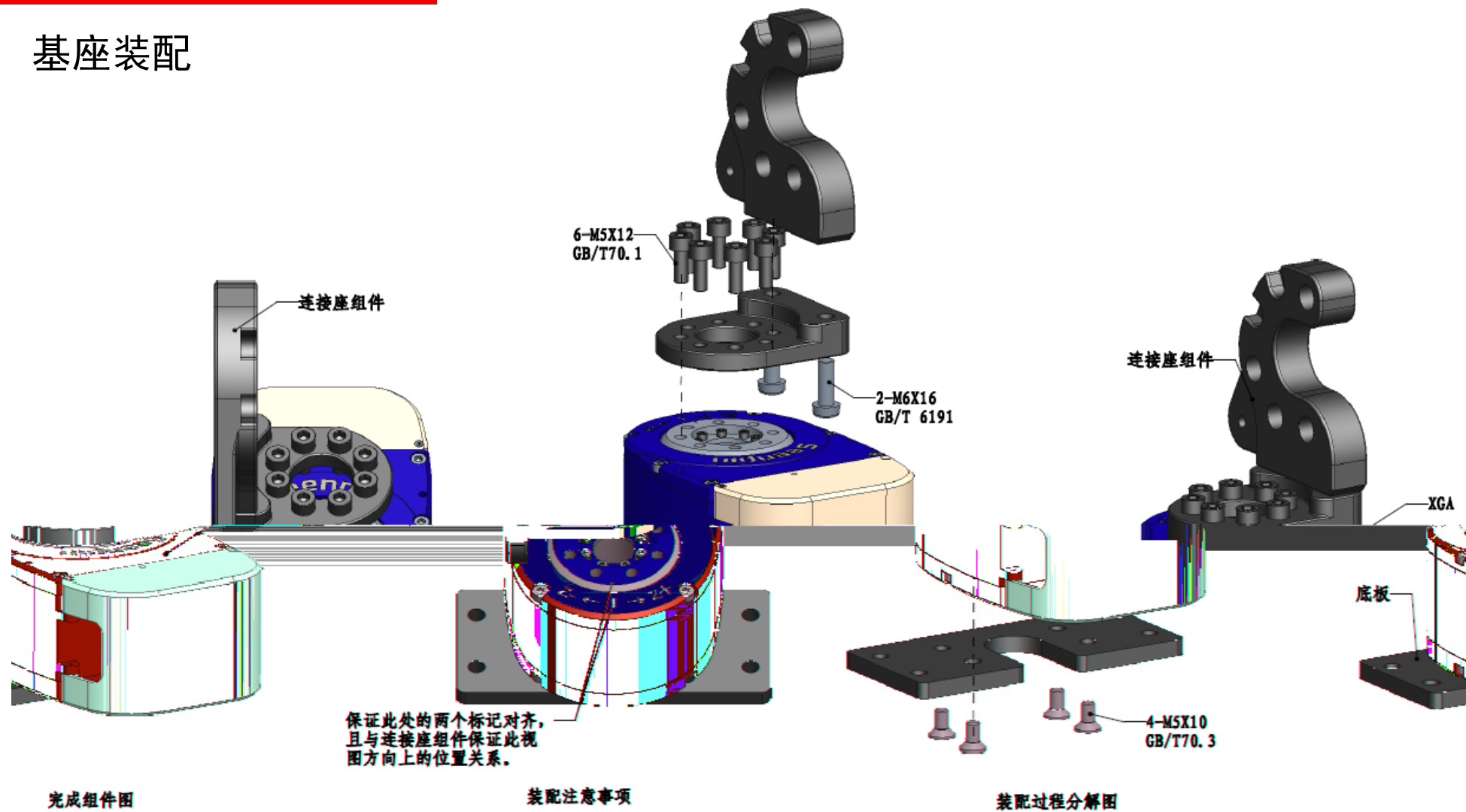

完成组件图

装配注意事项

装配过程分解图

整臂装配顺序

- 肩关节装配

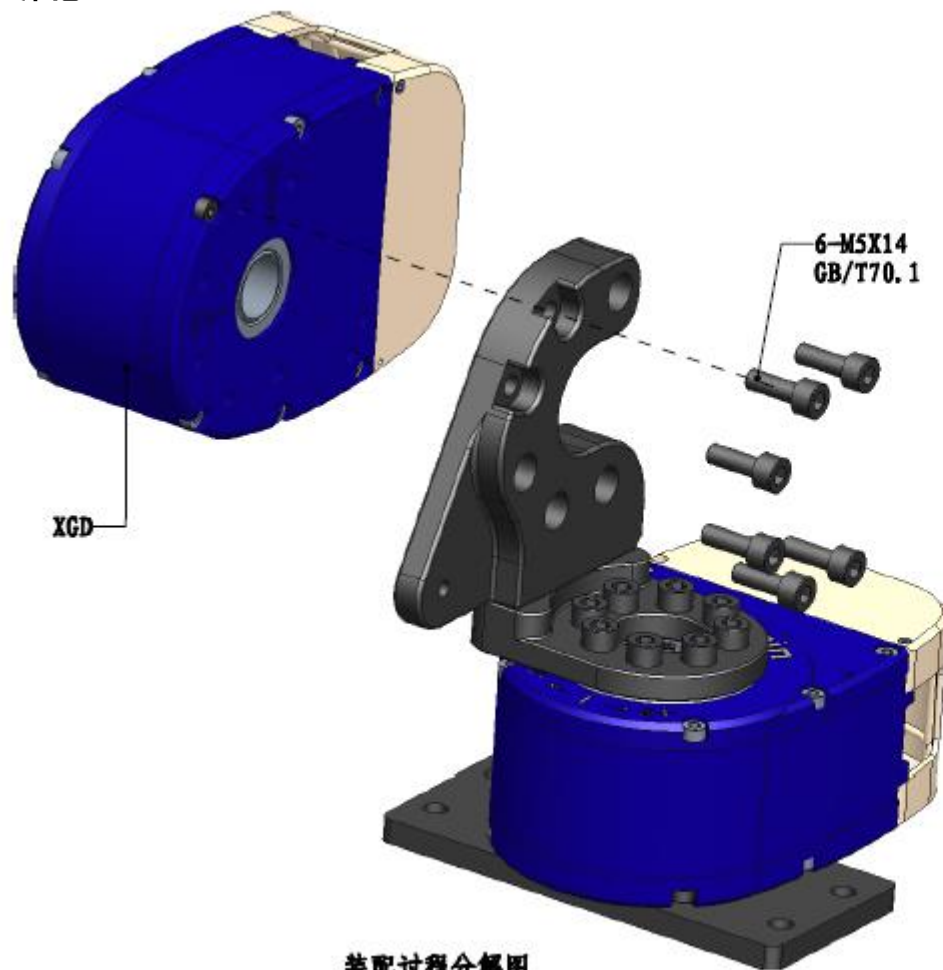

装配过程分解图

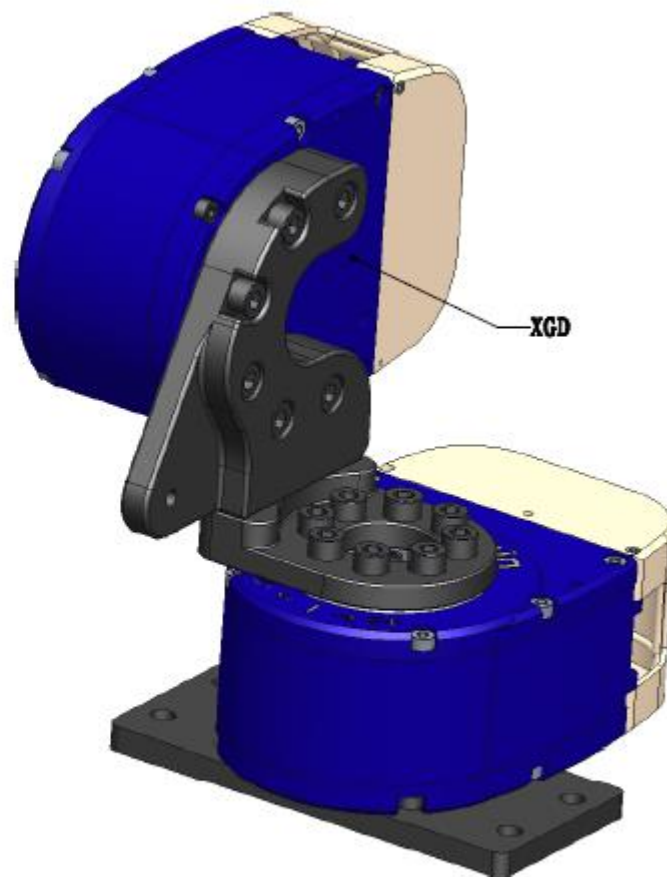

完成组件图

整臂装配顺序

- 前（后）臂杆装配

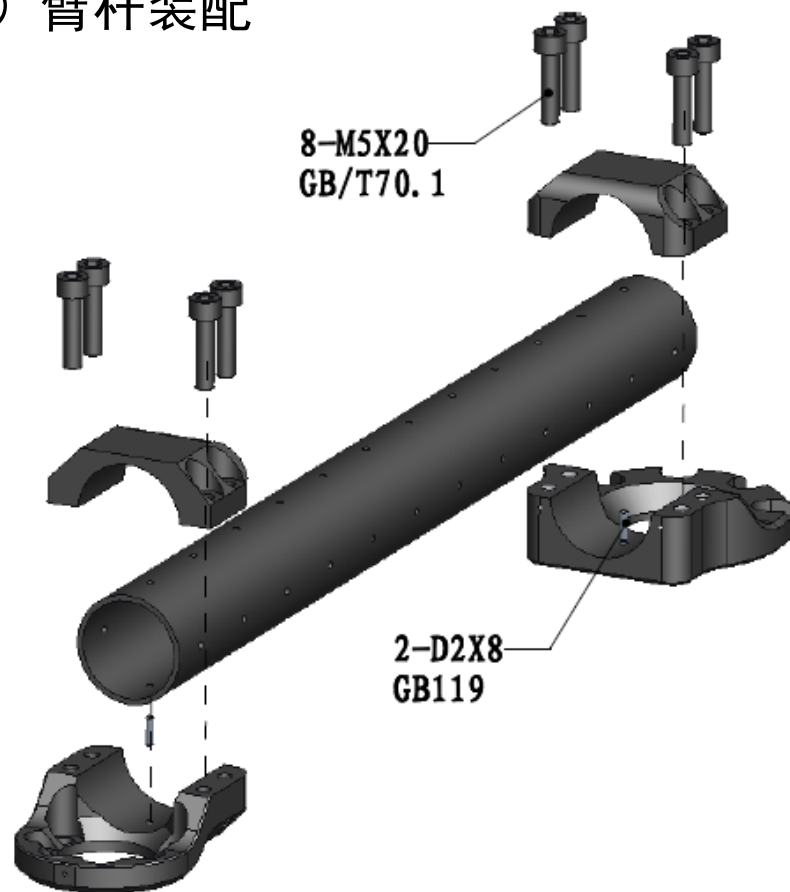

装配过程分解图

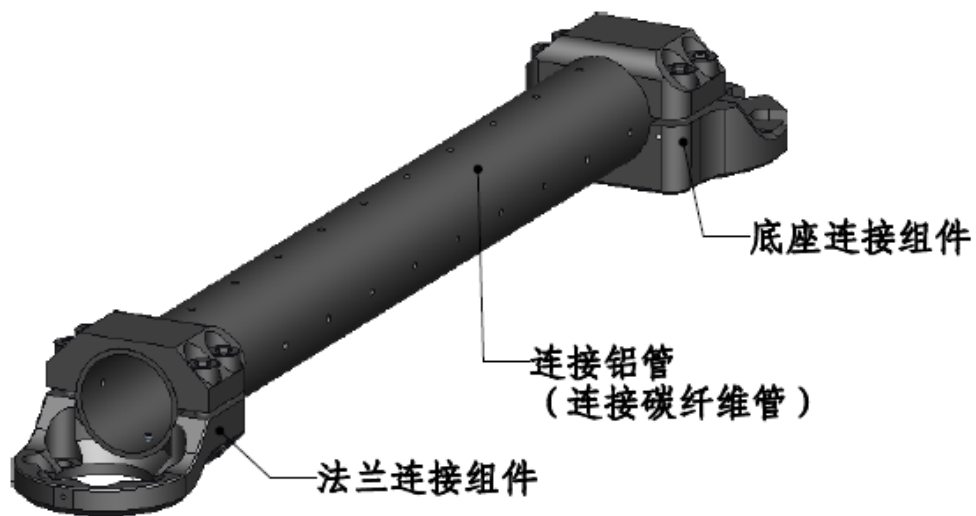

完成组件图

整臂装配顺序

- 前臂装配

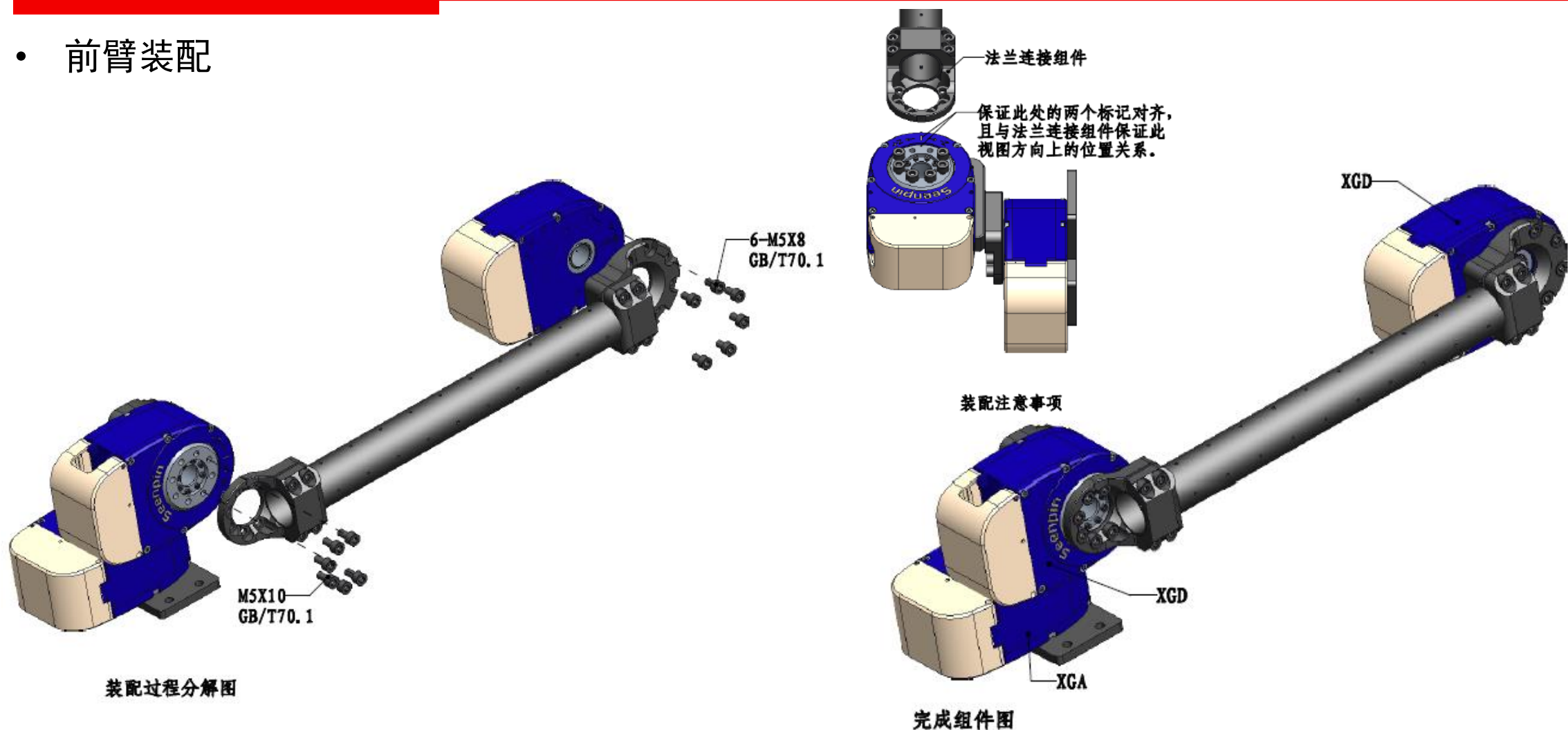

整臂装配顺序

- 后臂装配

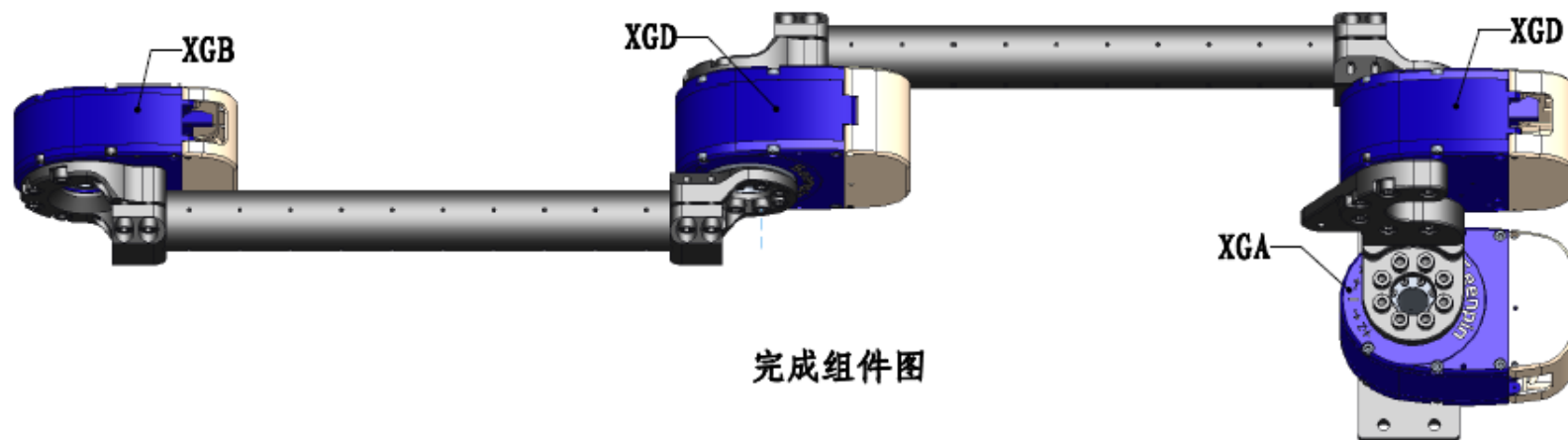
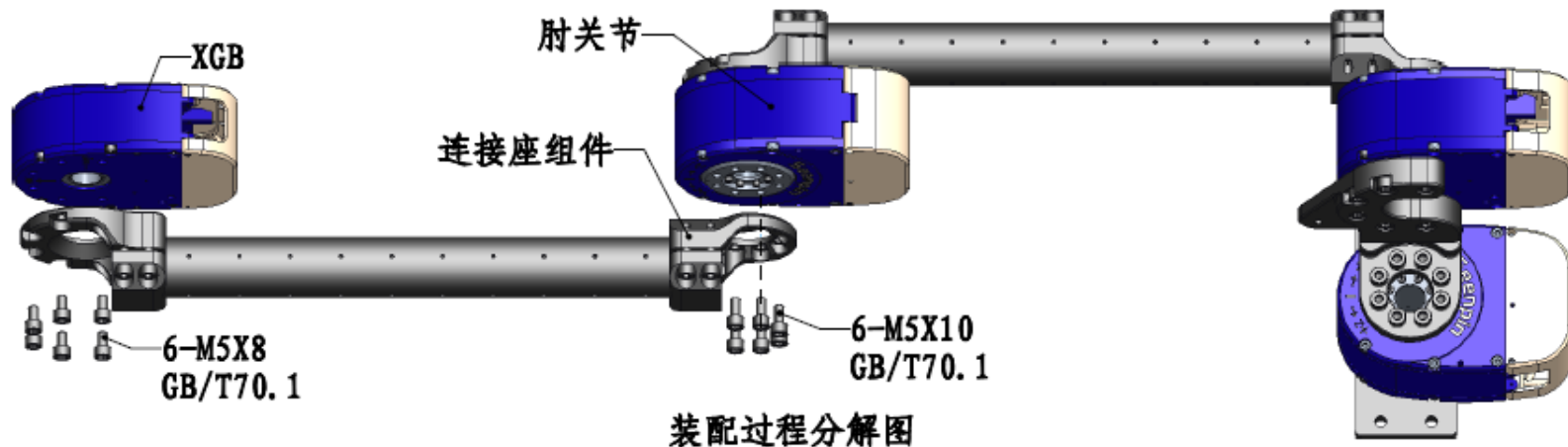
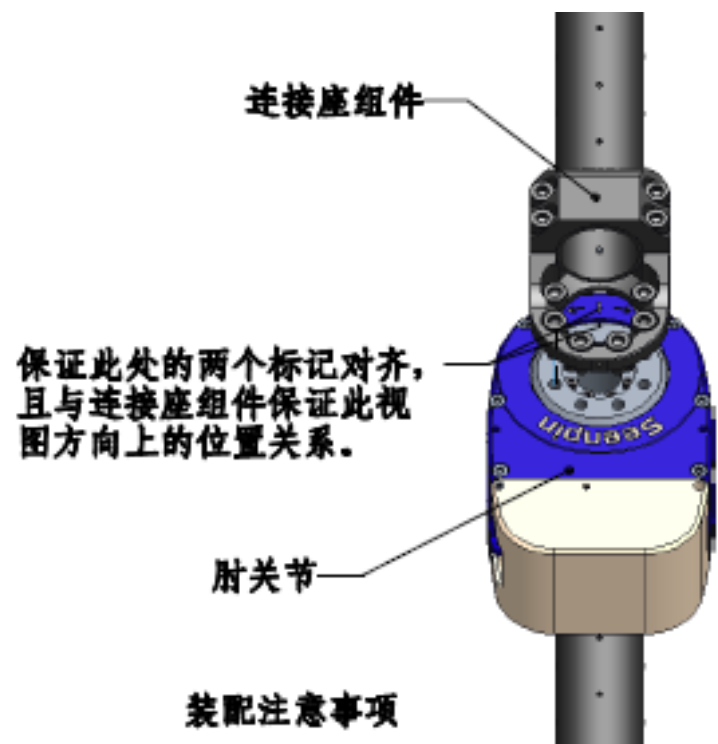

整臂装配顺序

- 腕部装配

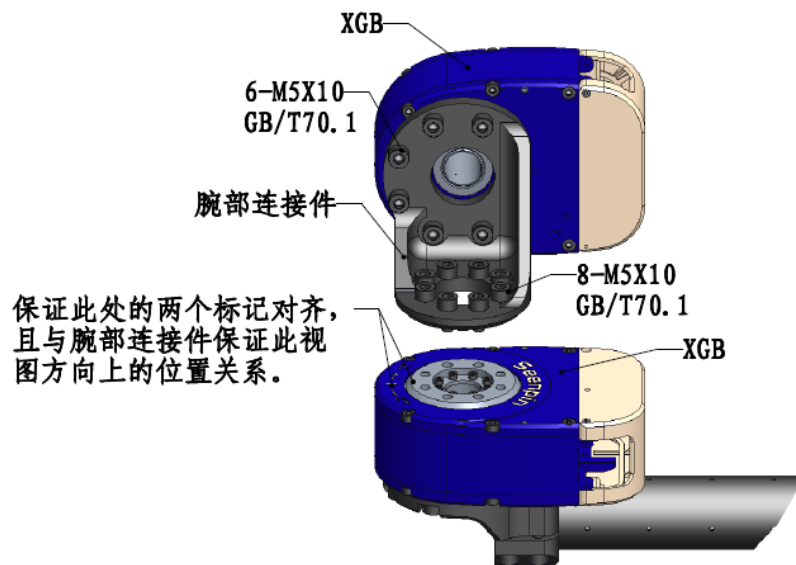

装配过程分解图及注意事项

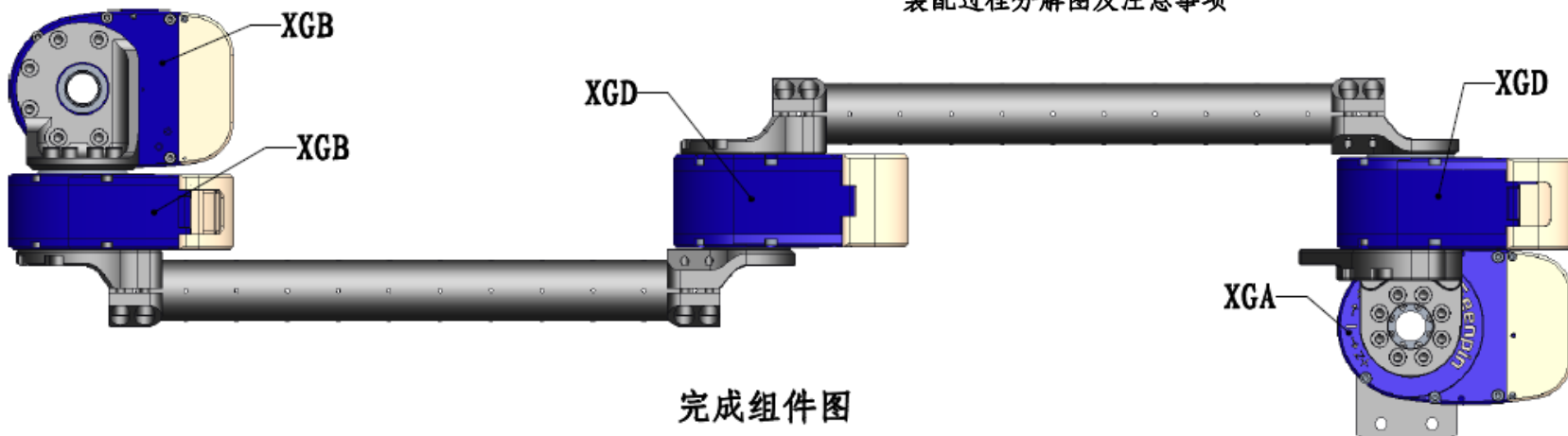

整臂装配顺序

- 腕部装配

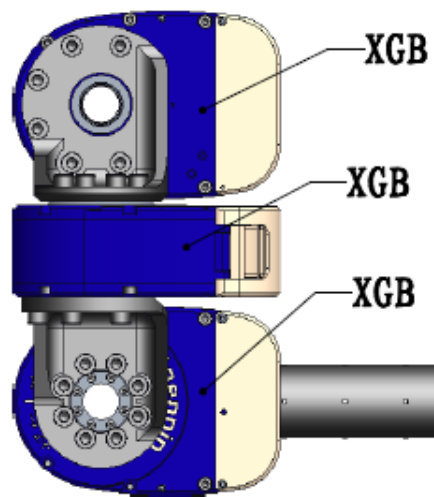

保证此处的两个标记对齐，
且与腕部连接件保证此视
图方向上的位置关系。

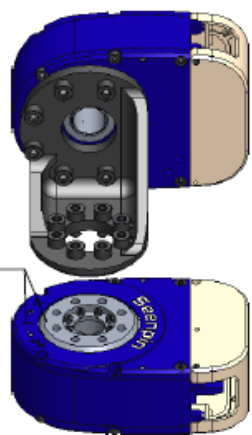

装配注意事项

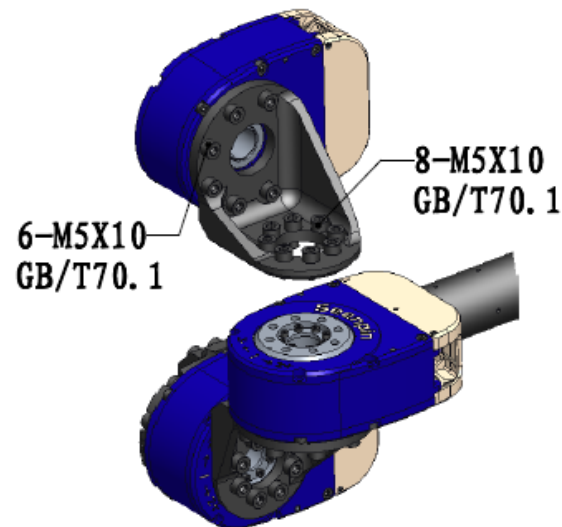

装配过程分解图



完成组件图

整臂装配顺序

- 机械臂初始零位状态

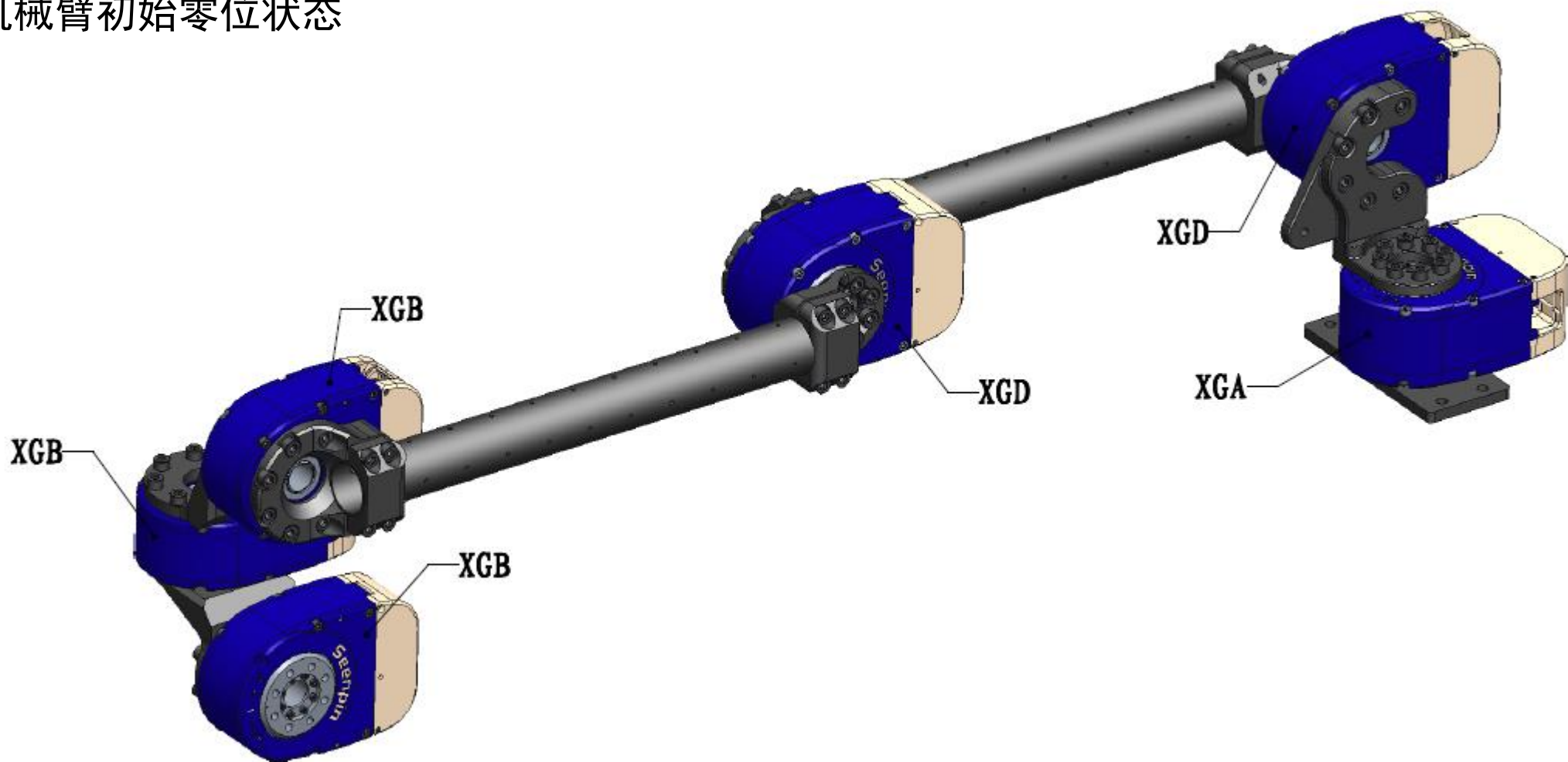

整臂装配顺序

- 夹抓装配

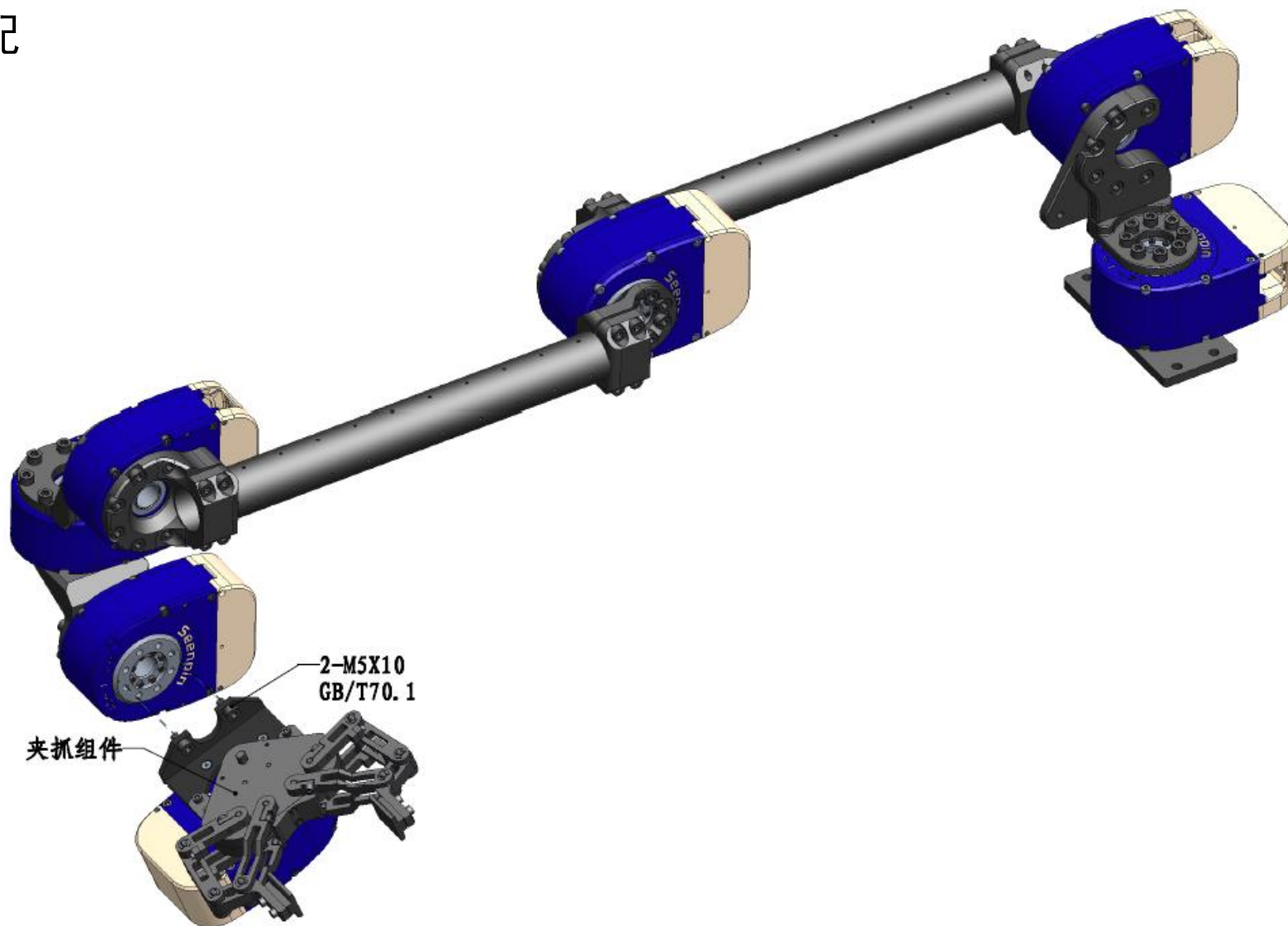

整臂装配顺序

- 布线图

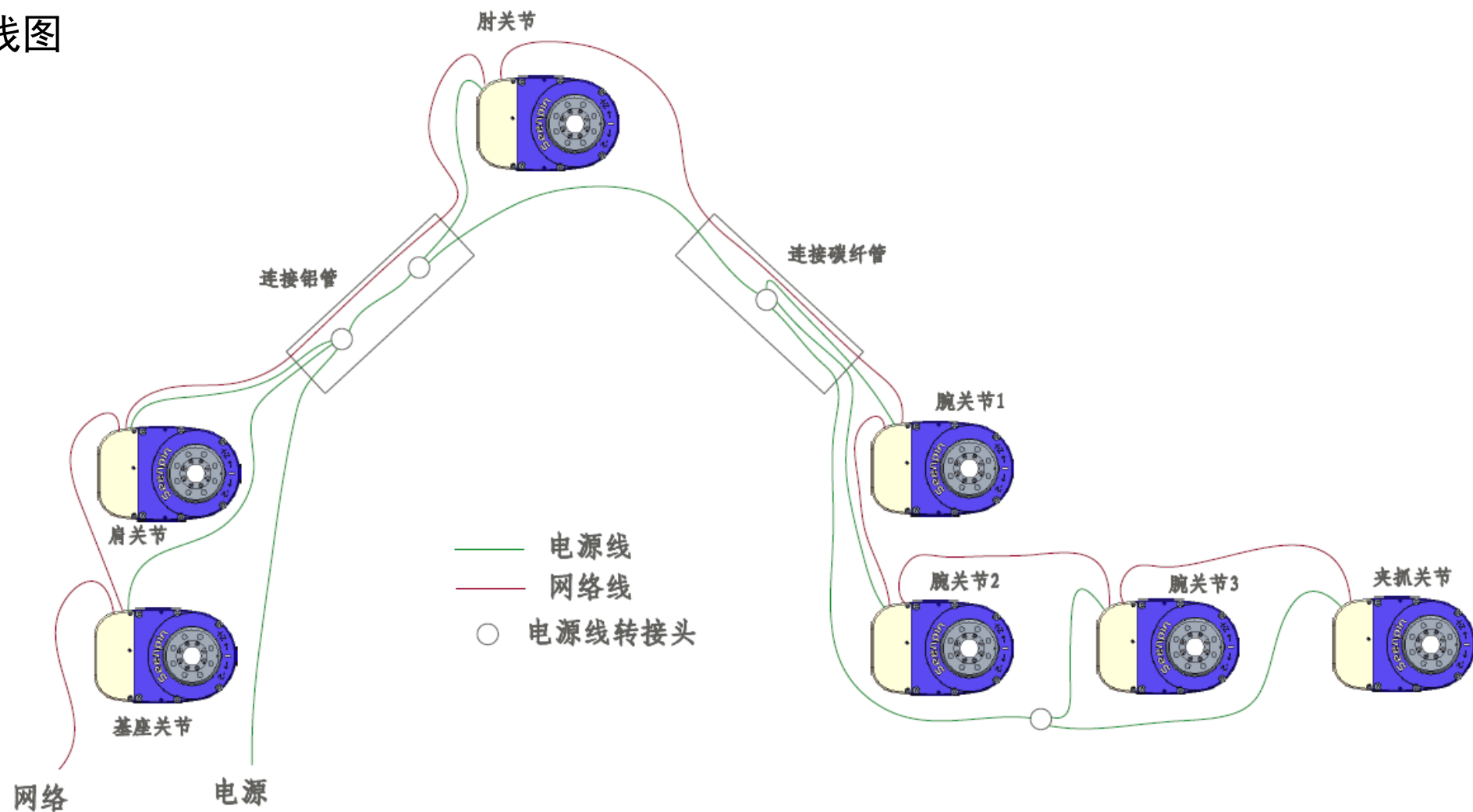

整臂装配顺序

- 塑料外罩壳装配

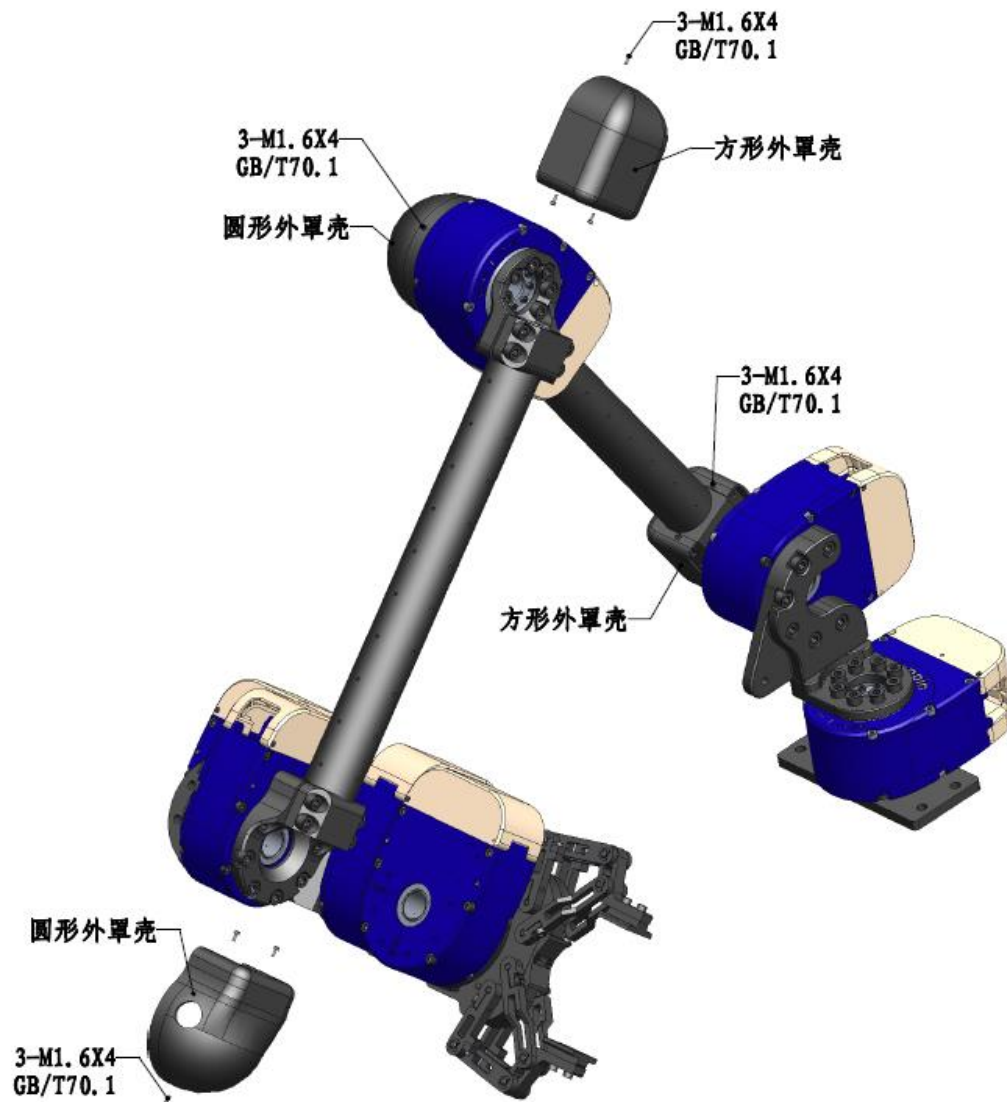

Seenpin 新剑

Company website: www.seenpin.com

